

REVISIONS

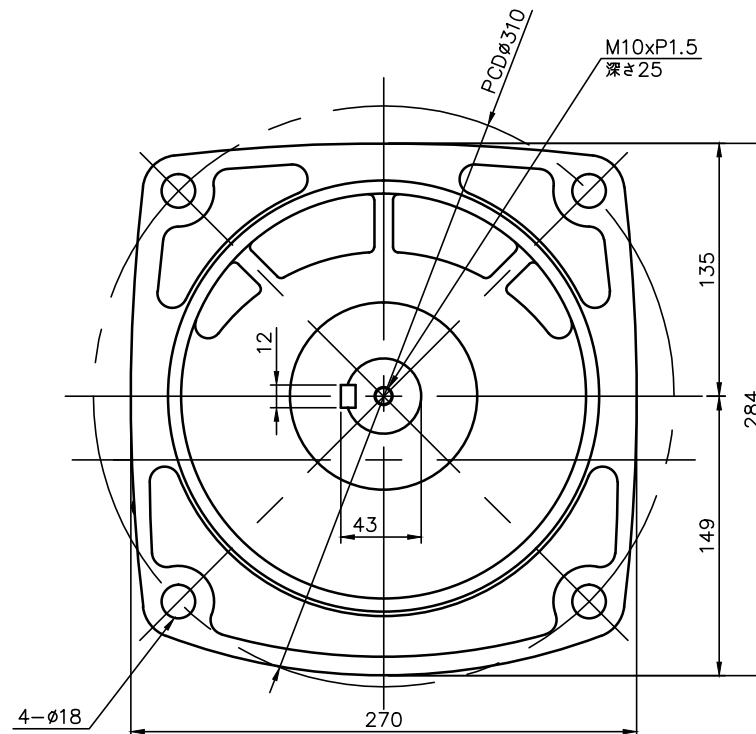
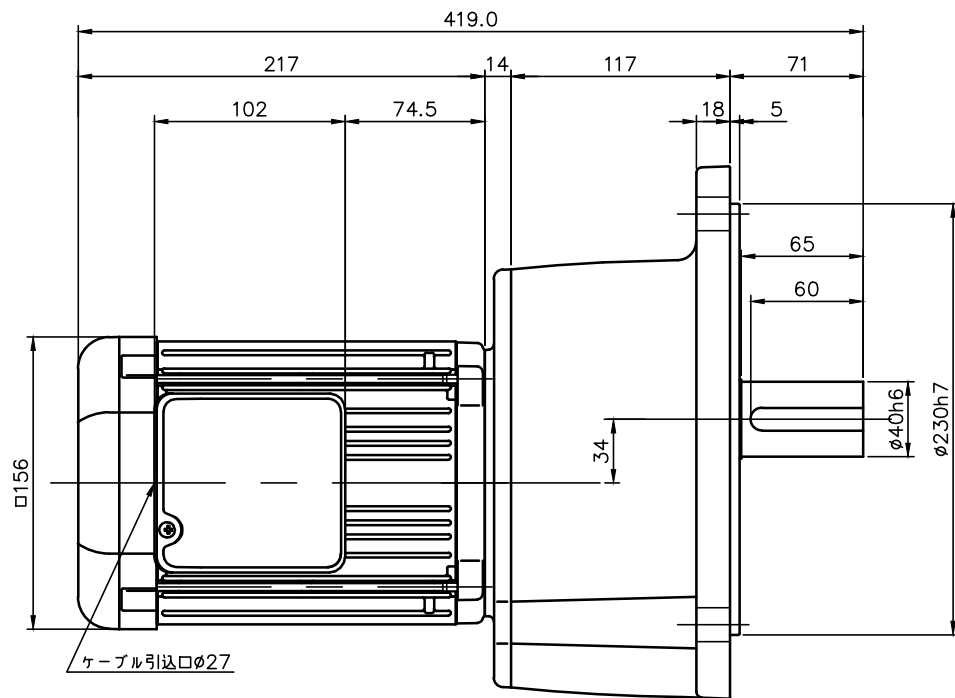

減速機仕様 REDUCER SPECIFICATION	
名称 TYPE	GTR
枠番 FRAME NO.	40
減速比 RATIO	100 120 160 200
潤滑 LUBRICATION	グリース (MANSEL CODE: 9B6/0.5)
塗装 PAINT COLOR	グレー (MANSEL CODE: 9B6/0.5)

モータ仕様 MOTOR SPECIFICATION	
名称 TYPE	三相誘導電動機 THREE PHASE INDUCTION MOTOR
冷却方式 COOLING METHOD	全閉外扇形 TOTALLY ENCLOSED FAN COOLED
出力 OUTPUT	0.75 kW
定格 RATING	S1 CONT.
耐熱クラス THERMAL CLASS	F
保護構造 IP RATING	IP44

モータ仕様 MOTOR SPECIFICATION							
××	電圧 VOLTAGE	周波数 FREQUENCY	回転速度 ROTATION SPEED	電流値 CURRENT VALUE	対応規格 COMPLIANT STANDARDS	高効率保証 EFFICIENCY STANDARDS	
NN	200 V	50 Hz	1440 r/min	3.2 A	UL/CE/CCC	< IE3 > USA/CHN/KOR	
	200 V	60 Hz	1720 r/min	3.0 A			
	220 V	60 Hz	1740 r/min	2.9 A			
WN	380 V	50 Hz	1430 r/min	1.65 A			
	400 V	50 Hz	1440 r/min	1.60 A			
	400 V	60 Hz	1730 r/min	1.50 A			
KN	220 V	60 Hz	1750 r/min	2.8 A		< IE3 > USA/CHN	
	380 V	60 Hz	1750 r/min	1.6 A			
	220 V	50 Hz	1430 r/min	2.8 A			
CN	230 V	50 Hz	1440 r/min	2.7 A			
	380 V	50 Hz	1430 r/min	1.65 A			
	208 V	60 Hz	1740 r/min	2.9 A			
AN	230 V	60 Hz	1750 r/min	2.8 A	< IE3 > USA/CHN		
	460 V	60 Hz	1750 r/min	1.4 A			
	400 V	50 Hz	1440 r/min	1.6 A			
EN	415 V	50 Hz	1440 r/min	1.50 A		< IE3 > USA	
	440 V	50 Hz	1450 r/min	1.50 A			
	480 V	60 Hz	1750 r/min	1.35 A			
MA	575 V	60 Hz	1750 r/min	1.10 A			

- 製品型式「□□□」は減速比によって入る文字数が変わります。
Number of characters on product model「□□□」varies depending on the reduction ratio.
- 製品型式「* *」には「NN」「WN」「KN」「CN」「AN」「EN」「MA」が入ります
Replace product model「* *」with「NN」「WN」「KN」「CN」「AN」「EN」「MA」.
- ターミナルボックスの引出口には膜付グロメットが取り付けられています。
Membrane grommet is attached to the outlet of terminal box.

TITLE		G3F 40N □□□ - MD08T * * TN			
		外形寸法図 DIMENSION OF MODEL			
DRAWING NO.		G3F 40N - MD08TTN			
USER					
NOTICE					
APPROVE	H.Hayashi	SCALE	1: 4	UNIT	DATE
CHECK	M.Iijima				
DESIGN	A.Kobayashi				
		UNIT		DATE	
		mm		2019.02.08	
NISSEI CORPORATION					