

REVISIONS

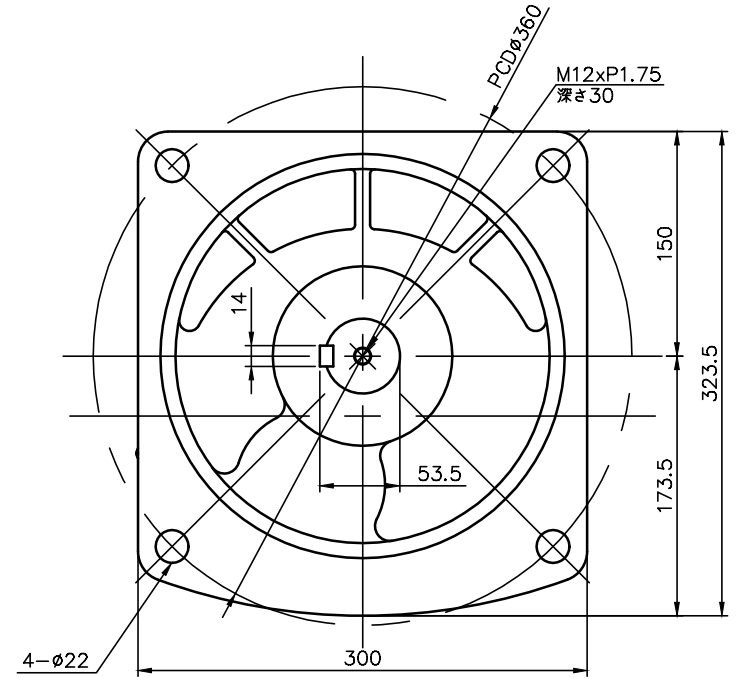
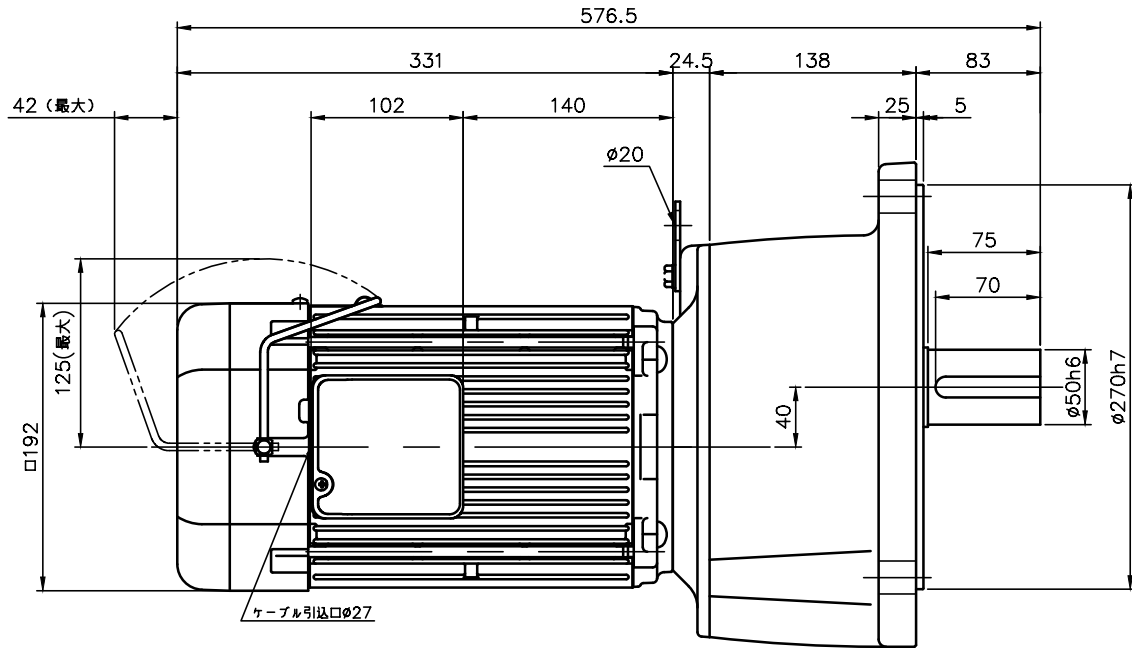

減速機仕様 REDUCER SPECIFICATION		
名称 TYPE	GTR	
枠番 FRAME NO.	50	
減速比 RATIO	30 40 50 60 80 100	
潤滑 LUBRICATION	グリース GREASE	
塗装 PAINT COLOR	グレー (マンセル値 9B6/0.5) GREY (MANSEL CODE: 9B6/0.5)	

モータ仕様 MOTOR SPECIFICATION	
名称 TYPE	三相誘導電動機 THREE PHASE INDUCTION MOTOR
冷却方式 COOLING METHOD	全閉外扇形 TOTALLY ENCLOSED FAN COOLED
出力 OUTPUT	2.2 kW
定格 RATING	S1 CONT.
耐熱クラス THERMAL CLASS	F
保護構造 IP RATING	IP44
電磁ブレーキ仕様 BRAKE SPECIFICATION	
型式 MODEL	220_B2
方式 BRAKE TYPE	無励磁作動形 (スプリングクローズ) POWER-OFF (SPRING CLOSE)
励磁電圧 EXCITATION VOLTAGE	DC90V
容量 CAPACITY	25W (AT 75°C)
静摩擦トルク STATIC FRICTION TORQUE	21.6N・m
動摩擦トルク DYNAMIC FRICTION TORQUE	17.3N・m

モータ仕様 MOTOR SPECIFICATION							
区分 DIVISION	電圧 VOLTAGE	周波数 FREQUENCY	回転速度 ROTATION SPEED	電流値 CURRENT VALUE	対応規格 COMPLIANT STANDARDS	高効率規格 EFFICIENCY STANDARDS	
NN	200 V	50 Hz	1470 r/min	9.3 A	UL/CE	< IE3 > USA/CHN /EUR/KOR	
	200 V	60 Hz	1760 r/min	8.6 A			
	220 V	60 Hz	1770 r/min	8.2 A			
KN	220 V	60 Hz	1770 r/min	8.3 A		UL/CE/cUL	< IE3 > USA/CHN /EUR
	380 V	60 Hz	1770 r/min	4.8 A			
	220 V	50 Hz	1460 r/min	7.9 A			
CN	230 V	50 Hz	1470 r/min	7.7 A	UL/CE/cUL		< IE3 > USA/CHN /EUR/CAN
	380 V	50 Hz	1440 r/min	4.5 A			
	230 V	60 Hz	1770 r/min	7.9 A			
UN	460 V	60 Hz	1770 r/min	4.0 A		UL/cUL	< IE3 > USA/CHN
	400 V	50 Hz	1470 r/min	4.5 A			
	575 V	60 Hz	1760 r/min	3.3 A			

● 製品型式「□□□」は減速比によって入る文字数が変わります。
Number of characters on product model「□□□」, varies depending on the reduction ratio.

● 製品型式「* * *」には区分の記号のいずれかが入ります
Replace product model「* * *」 with one of the division symbols

TITLE				G3F50N□□□-MR22T* * TJ2			
				外形寸法図 DIMENSION OF MODEL			
DRAWING NO.				G3F50N-MR22TJ2			
USER							
NOTICE							
APPROVE	Y.Fukatsu	SCALE	1:5		UNIT	DATE	
CHECK	Y.Miura				mm	2024.03.22	
DESIGN	H.Sugiyayashi				NISSEI CORPORATION		