

REVISIONS

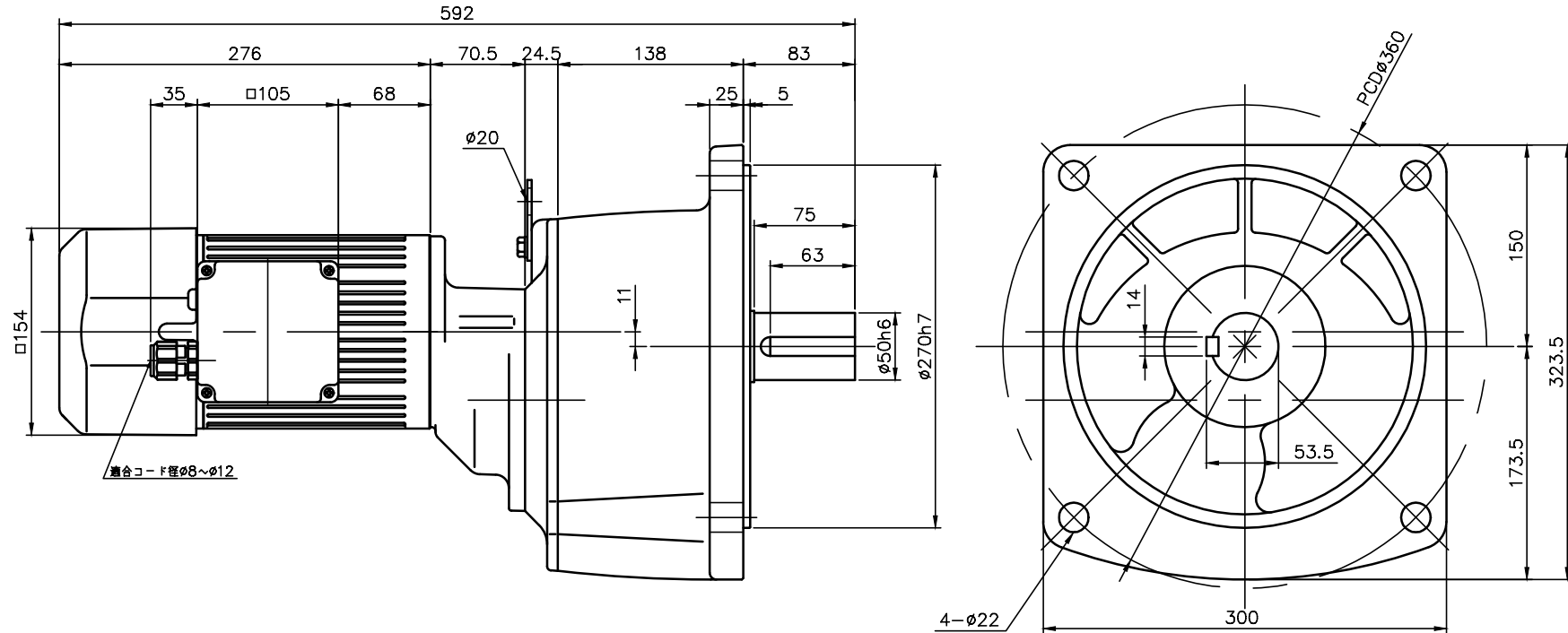

減速機仕様 REDUCER SPECIFICATION		
名称 TYPE	GTR	
枠番 FRAME NO.	50	
減速比 RATIO	300 375 450	
潤滑 LUBRICATION	グリース GREASE	
塗装 PAINT COLOR	グレー (マンセル値 9B6/0.5) GREY (MANSEL CODE: 9B6/0.5)	

モータ仕様 MOTOR SPECIFICATION		
名称 TYPE	三相誘導電動機 THREE PHASE INDUCTION MOTOR	
冷却方式 COOLING METHOD	全閉外扇形 TOTALLY ENCLOSED FAN COOLED	
出力 OUTPUT	0.75 kW	
定格 RATING	S1 CONT.	
耐熱クラス THERMAL CLASS	F	
保護構造 IP RATING	IP65	
電磁ブレーキ仕様 BRAKE SPECIFICATION		
型式 MODEL	075_V4	
方式 BRAKE TYPE	無励磁作動形 (スプリングクローズ) POWER-OFF (SPRING CLOSE)	
励磁電圧 EXCITATION VOLTAGE	DC180V	
容量 CAPACITY	19W (AT 75°C)	
静摩擦トルク STATIC FRICTION TORQUE	7.35N・m	
動摩擦トルク DYNAMIC FRICTION TORQUE	5.88N・m	

モータ仕様 MOTOR SPECIFICATION								
区分 DIVISION	電圧 VOLTAGE	周波数 FREQUENCY	回転速度 ROTATION SPEED	電流値 CURRENT VALUE	対応規格 COMPLIANT STANDARDS	高効率規格 EFFICIENCY STANDARDS		
WN	380 V	50 Hz	1440 r/min	1.73 A	UL/CE/CCC	< IE3 > USA/CHN /EUR/KOR		
	400 V	50 Hz	1450 r/min	1.72 A				
	400 V	60 Hz	1740 r/min	1.58 A				
	440 V	60 Hz	1750 r/min	1.54 A				
DN	220 V	50 Hz	1450 r/min	3.1 A				
	220 V	60 Hz	1740 r/min	2.9 A				
	380 V	50 Hz	1450 r/min	1.8 A				
	380 V	60 Hz	1740 r/min	1.7 A				
KN	220 V	60 Hz	1740 r/min	2.9 A				
	380 V	60 Hz	1740 r/min	1.7 A				
CN	220 V	50 Hz	1450 r/min	3.0 A			< IE3 > USA/CHN /EUR	
	230 V	50 Hz	1450 r/min	3.0 A				
	380 V	50 Hz	1450 r/min	1.7 A				
UN	230 V	60 Hz	1760 r/min	3.1 A	UL/CE/CCC cUL	< IE3 > USA/CHN /EUR/CAN		
	460 V	60 Hz	1760 r/min	1.5 A				
	400 V	50 Hz	1450 r/min	1.7 A				
EN	415 V	50 Hz	1440 r/min	1.54 A				
	440 V	50 Hz	1450 r/min	1.52 A				
	480 V	60 Hz	1750 r/min	1.36 A				

- 製品型式「□□□」は減速比によって入る文字数が変わります。  
Number of characters on product model「□□□」, varies depending on the reduction ratio.
- 製品型式「\*\*」には区分の記号のいずれかが入ります  
Replace product model「\*\*」 with one of the division symbols
- 出力軸・キーの材質は SUS420J2 を使用しています。  
THE MATERIAL OF THE OUTPUT SHAFT AND KEY IS SUS420J2.
- ねじ類は鋼製となっています。  
THE SCREWS ARE MADE OF STEEL.

TITLE				G3F50S□□□-WR08T**EV4			
DRAWING NO.				G3F50S-WR08TEV4			
USER							
NOTICE							
APPROVE	Y.Fukatsu	SCALE	1:5	UNIT	mm	DATE	2024.03.22
CHECK	Y.Miura			NISSEI CORPORATION			
DESIGN	H.Sugiyayashi						