

適合コード径φ8~φ12

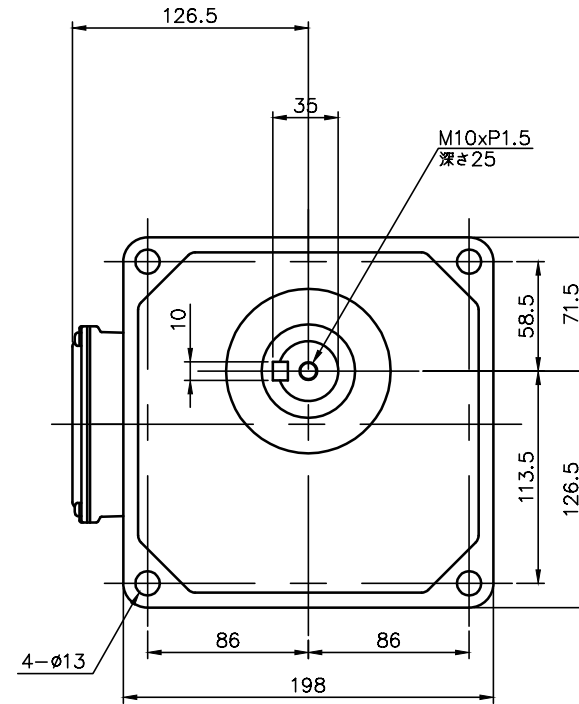

| 減速機仕様 REDUCER SPECIFICATION | | |
|-----------------------------|---|--|
| 名称 TYPE | GTR | |
| 枠番 FRAME NO. | 32 | |
| 減速比 RATIO | 30 40 50 60 80 100 | |
| 潤滑 LUBRICATION | グリース GREASE | |
| 塗装 PAINT COLOR | グレー (マンセル値 9B6/0.5) GREY (MANSEL CODE: 9B6/0.5) | |

| モータ仕様 MOTOR SPECIFICATION | | |
|---------------------------|-------------------------------------|--|
| 名称 TYPE | 三相誘導電動機 THREE PHASE INDUCTION MOTOR | |
| 冷却方式 COOLING METHOD | 全閉外扇形 TOTALLY ENCLOSED FAN COOLED | |
| 出力 OUTPUT | 0.75 kW | |
| 定格 RATING | S1 CONT. | |
| 耐熱クラス THERMAL CLASS | F | |
| 保護構造 IP RATING | IP65 | |

| モータ仕様 MOTOR SPECIFICATION | | | | | | |
|---------------------------|------------|---------------|---------------------|-------------------|--------------------------|----------------------------|
| 区分 DIVISION | 電圧 VOLTAGE | 周波数 FREQUENCY | 回転速度 ROTATION SPEED | 電流値 CURRENT VALUE | 対応規格 COMPLIANT STANDARDS | 高効率規格 EFFICIENCY STANDARDS |
| NN | 200 V | 50 Hz | 1450 r/min | 3.5 A | UL/CE/CCC | < IE3 > USA/CHN /EUR/KOR |
| | 200 V | 60 Hz | 1740 r/min | 3.2 A | | |
| | 220 V | 60 Hz | 1750 r/min | 3.1 A | | |
| WN | 380 V | 50 Hz | 1440 r/min | 1.73 A | | |
| | 400 V | 50 Hz | 1450 r/min | 1.72 A | | |
| | 400 V | 60 Hz | 1740 r/min | 1.58 A | | |
| DN | 220 V | 50 Hz | 1450 r/min | 3.1 A | UL/CE/CCC | < IE3 > USA/CHN /EUR |
| | 220 V | 60 Hz | 1740 r/min | 2.9 A | | |
| | 380 V | 50 Hz | 1450 r/min | 1.8 A | | |
| KN | 220 V | 60 Hz | 1740 r/min | 2.9 A | UL/CE/CCC | < IE3 > USA/CHN /EUR |
| | 380 V | 60 Hz | 1740 r/min | 1.7 A | | |
| | 220 V | 50 Hz | 1450 r/min | 3.0 A | | |
| CN | 230 V | 50 Hz | 1450 r/min | 3.0 A | UL/CE/CCC | < IE3 > USA/CHN /EUR |
| | 380 V | 50 Hz | 1440 r/min | 1.7 A | | |
| | 230 V | 60 Hz | 1760 r/min | 3.1 A | | |
| UN | 460 V | 60 Hz | 1760 r/min | 1.5 A | UL/CE/CCC | < IE3 > USA/CHN /EUR/CAN |
| | 400 V | 50 Hz | 1450 r/min | 1.7 A | | |
| | 415 V | 50 Hz | 1440 r/min | 1.54 A | | |
| EN | 440 V | 50 Hz | 1450 r/min | 1.52 A | UL/CE/CCC | < IE3 > USA/CHN /EUR/CAN |
| | 480 V | 60 Hz | 1750 r/min | 1.36 A | | |
| | 575 V | 60 Hz | 1750 r/min | 1.16 A | | |
| MA | 575 V | 60 Hz | 1750 r/min | 1.16 A | UL/cUL | < IE3 > USA/CAN |

- 製品型式「□□□」は減速比によって入る文字数が変わります。
Number of characters on product model「□□□」, varies depending on the reduction ratio.
- 製品型式「**」には区分の記号のいずれかが入ります
Replace product model「**」 with one of the division symbols
- 出力軸・キーの材質は S43C を使用しています。
THE MATERIAL OF THE OUTPUT SHAFT AND KEY IS S43C.
- ねじ類は鋼製となっています。
THE SCREWS ARE MADE OF STEEL.

| | | | | | | | |
|--------------------|---------------|-------|-----|---------------------|----|------|------------|
| TITLE | | | | G3K32N□□□-WR08T**EN | | | |
| DRAWING NO. | | | | G3K32N-WR08TEN | | | |
| USER | | | | | | | |
| NOTICE | | | | | | | |
| APPROVE | Y.Fukatsu | SCALE | 1:4 | UNIT | mm | DATE | 2024.03.22 |
| CHECK | Y.Miura | | | | | | |
| DESIGN | H.Sugibayashi | | | | | | |
| NISSEI CORPORATION | | | | | | | |