

REVISIONS

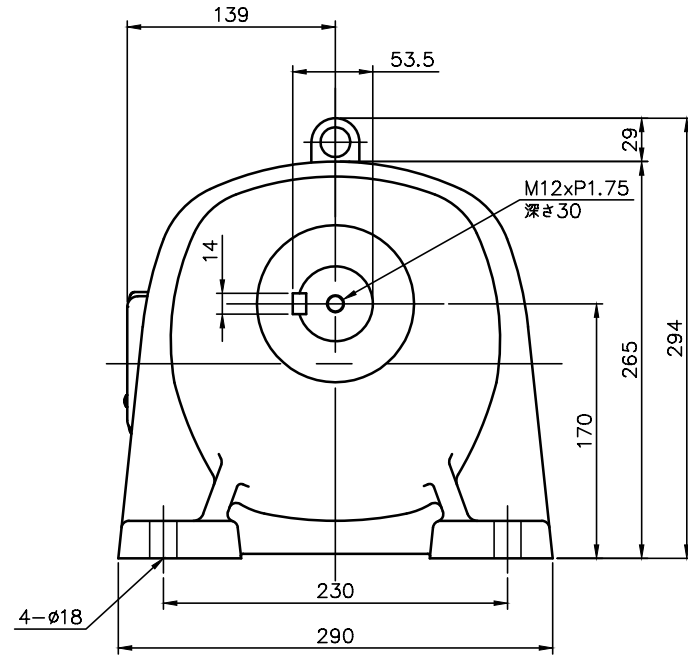
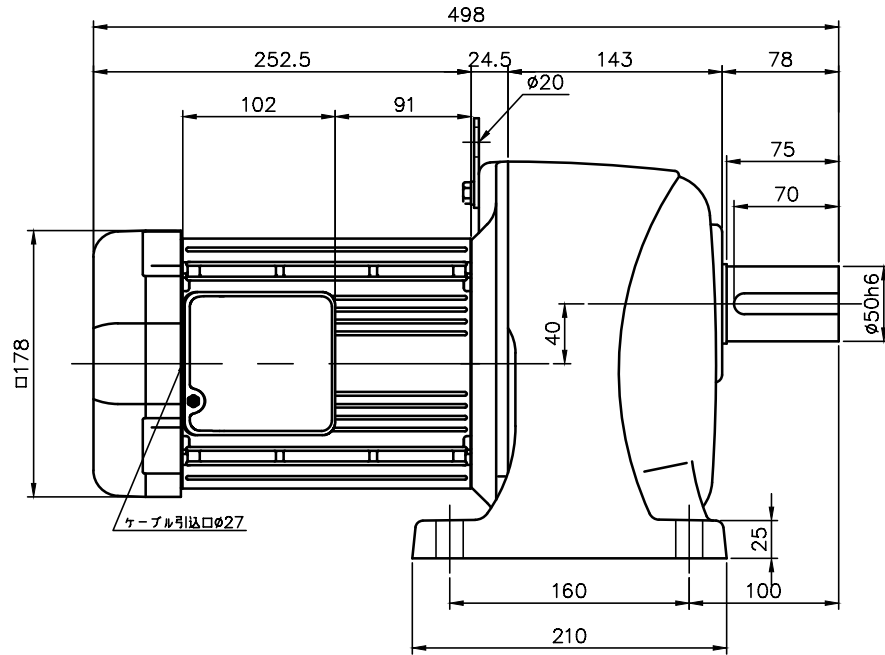

減速機仕様 REDUCER SPECIFICATION		
名称 TYPE	GTR	
枠番 FRAME NO.	50	
減速比 RATIO	100 120 160 200	
潤滑 LUBRICATION	グリース (MANSEL値 9B6/0.5)	
塗装 PAINT COLOR	グレー (MANSEL CODE: 9B6/0.5)	

モータ仕様 MOTOR SPECIFICATION		
名称 TYPE	三相誘導電動機 THREE PHASE INDUCTION MOTOR	
冷却方式 COOLING METHOD	全閉外扇形 TOTALLY ENCLOSED FAN COOLED	
出力 OUT PUT	1.5 kW	
定格 RATING	S1 CONT.	
耐熱クラス THERMAL CLASS	F	
保護構造 IP RATING	IP44	

モータ仕様 MOTOR SPECIFICATION							
区分 DIVISION	電圧 VOLTAGE	周波数 FREQUENCY	回転速度 ROTATION SPEED	電流値 CURRENT VALUE	対応規格 COMPLIANT STANDARDS	高効率規格 EFFICIENCY STANDARDS	
NN	200 V	50 Hz	1450 r/min	6.7 A	UL/CE	< IE3 > USA/CHN /EUR/KOR	
	200 V	60 Hz	1740 r/min	6.1 A			
	220 V	60 Hz	1760 r/min	5.9 A			
WN	380 V	50 Hz	1450 r/min	3.4 A		UL/CE/cUL	< IE3 > USA/CHN /EUR
	400 V	50 Hz	1450 r/min	3.4 A			
	400 V	60 Hz	1750 r/min	3.1 A			
KN	440 V	60 Hz	1760 r/min	3.0 A	UL/cUL		< IE3 > USA/CAN
	220 V	60 Hz	1760 r/min	5.9 A			
	380 V	60 Hz	1760 r/min	3.4 A			
CN	220 V	50 Hz	1450 r/min	5.9 A		UL/CE/cUL	< IE3 > USA/CHN /EUR
	230 V	50 Hz	1450 r/min	5.9 A			
	380 V	50 Hz	1450 r/min	3.4 A			
UN	230 V	60 Hz	1760 r/min	5.9 A	UL/CE/cUL		< IE3 > USA/CHN /EUR/CAN
	460 V	60 Hz	1760 r/min	2.9 A			
	400 V	50 Hz	1450 r/min	3.3 A			
EN	415 V	50 Hz	1450 r/min	3.1 A		UL/cUL	< IE3 > USA/CAN
	440 V	50 Hz	1460 r/min	3.1 A			
	480 V	60 Hz	1760 r/min	2.8 A			
MA	575 V	60 Hz	1760 r/min	2.2 A			

● 製品型式「□□□」は減速比によって入る文字数が変わります。  
Number of characters on product model「□□□」, varies depending on the reduction ratio.

● 製品型式「\* \*」には区分の記号のいずれかが入ります  
Replace product model「\* \*」 with one of the division symbols

TITLE		G3L50N□□□-MR15T* * TN		
		外形寸法図 DIMENSION OF MODEL		
DRAWING NO.		G3L50N-MR15TTN		
USER				
NOTICE				
APPROVE	Y.Fukatsu	SCALE	UNIT	DATE
CHECK	Y.Miura	1:5	mm	2024.03.22
DESIGN	H.Sugiyayashi	NISSEI CORPORATION		