

REVISIONS

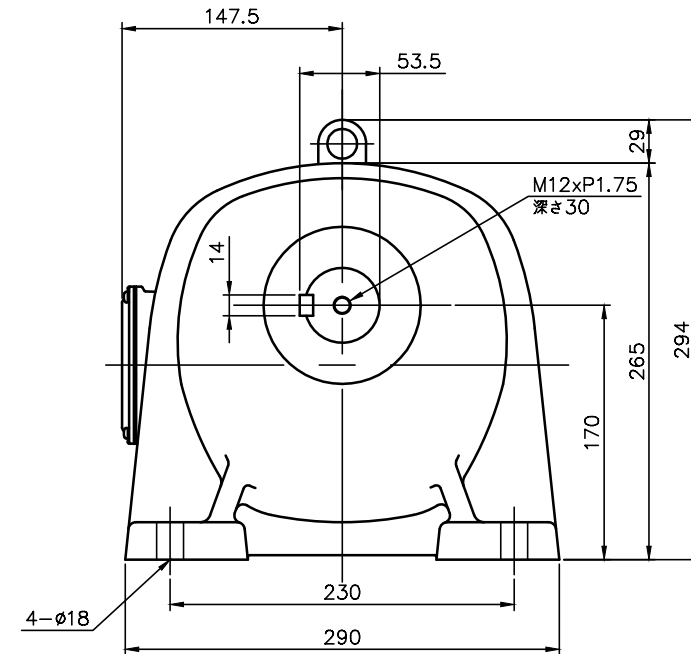
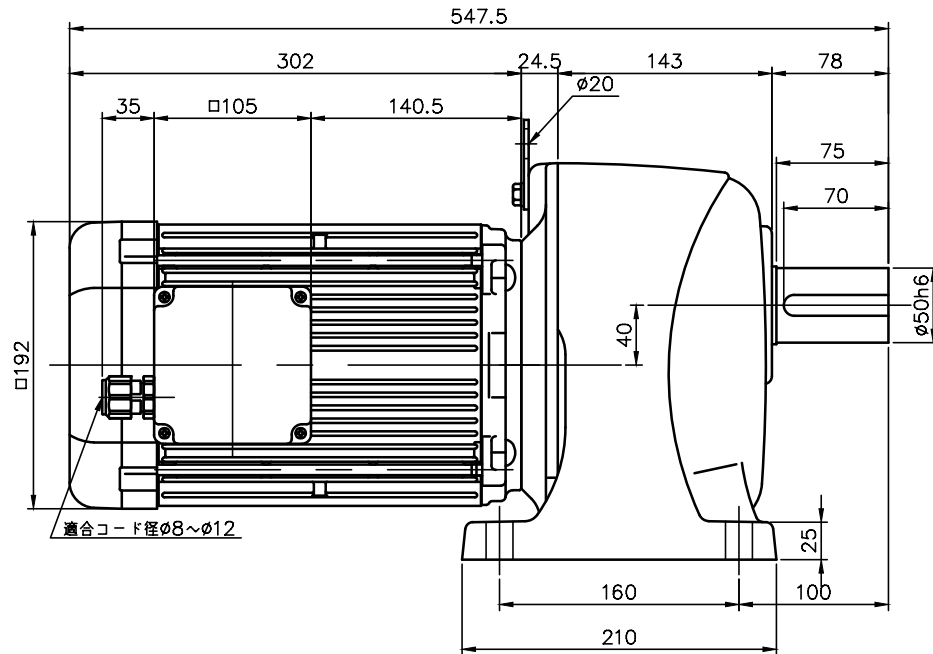

減速機仕様 REDUCER SPECIFICATION		
名称 TYPE	GTR	
枠番 FRAME NO.	50	
減速比 RATIO	30 40 50 60 80 100	
潤滑 LUBRICATION	グリース (MANSEL値 9B6/0.5)	
塗装 PAINT COLOR	グレー (MANSEL CODE: 9B6/0.5)	

モータ仕様 MOTOR SPECIFICATION		
名称 TYPE	三相誘導電動機 THREE PHASE INDUCTION MOTOR	
冷却方式 COOLING METHOD	全閉外扇形 TOTALLY ENCLOSED FAN COOLED	
出力 OUTPUT	2.2 kW	
定格 RATING	S1 CONT.	
耐熱クラス THERMAL CLASS	F	
保護構造 IP RATING	IP65	

モータ仕様 MOTOR SPECIFICATION							
区分 DIVISION	電圧 VOLTAGE	周波数 FREQUENCY	回転速度 ROTATION SPEED	電流値 CURRENT VALUE	対応規格 COMPLIANT STANDARDS	高効率規格 EFFICIENCY STANDARDS	
NN	200 V	50 Hz	1470 r/min	9.3 A	UL/CE	< IE3 > USA/CHN /EUR/KOR	
	200 V	60 Hz	1760 r/min	8.6 A			
	220 V	60 Hz	1770 r/min	8.2 A			
WN	380 V	50 Hz	1440 r/min	4.5 A			
	400 V	50 Hz	1450 r/min	4.4 A			
	400 V	60 Hz	1740 r/min	4.2 A			
KN	440 V	60 Hz	1750 r/min	3.9 A			
	220 V	60 Hz	1770 r/min	8.3 A			
CN	380 V	60 Hz	1770 r/min	4.8 A			
	220 V	50 Hz	1460 r/min	7.9 A		< IE3 > USA/CHN /EUR	
	230 V	50 Hz	1470 r/min	7.7 A			
UN	380 V	50 Hz	1440 r/min	4.5 A			
	230 V	60 Hz	1770 r/min	7.9 A			
	460 V	60 Hz	1770 r/min	4.0 A		< IE3 > USA/CHN /EUR/CAN	
EN	400 V	50 Hz	1470 r/min	4.5 A			
	415 V	50 Hz	1460 r/min	4.3 A			
	440 V	50 Hz	1470 r/min	4.3 A			
MA	480 V	60 Hz	1770 r/min	3.8 A			
	575 V	60 Hz	1760 r/min	3.3 A	UL/cUL	< IE3 > USA/CAN	

- 製品型式「□□□」は減速比によって入る文字数が変わります。
Number of characters on product model「□□□」, varies depending on the reduction ratio.
- 製品型式「**」には区分の記号のいずれかが入ります
Replace product model「**」 with one of the division symbols
- 出力軸・キーの材質は S43C を使用しています。
THE MATERIAL OF THE OUTPUT SHAFT AND KEY IS S43C.
- ねじ類は鋼製となっています。
THE SCREWS ARE MADE OF STEEL.

TITLE	G3L50N□□□-WR22T**EN 外形寸法図 DIMENSION OF MODEL				
DRAWING NO.	G3L50N-WR22TEN				
USER					
NOTICE					
APPROVE	Y.Fukatsu	SCALE	1:5	UNIT	mm
CHECK	Y.Miura			DATE	2024.03.22
DESIGN	H.Sugibayashi	NISSEI CORPORATION			